

GAYMAR®

Medi-Therm® III Hyper/Hypothermia Machine MTA6900

**Manual Mode
Automatic Mode
Monitor Mode**



LISTED 303L



STANDARD [NORME]
C22.2 No. 125 RISK
CLASS [CATEGORIE DE
RISQUES] NO. 2G

Operator's Manual

P/N 11027-000 9/00

www.gaymar.com P/N 11027-000 9/00

Table of Contents

<i>Section</i>	<i>Description</i>	<i>Page</i>
1.0	Safety Precautions	1
2.0	Description	2
3.0	Features	3
4.0	Operator Control Panel	4
5.0	Start-up Procedure	5
6.0	Shutdown Procedure	7
7.0	Modes of Operations	8
	Manual Mode	8
	Automatic Mode	10
	Monitor Mode	12
8.0	Patient Safety	14
9.0	Care of Medi-Therm III	16
10.0	Alerts/Troubleshooting	18
11.0	Blankets/Accessories	20
12.0	Customer Training	20
13.0	Warranty	20

Illustrations

<i>Figure</i>	<i>Description</i>	<i>Page</i>
1	Medi-Therm III System	2
2	Medi-Therm III Features	3
3	Medi-Therm III Control Panel	4
4	Pinch Clamps	5
5	Quick-disconnects	6
6	Clik-Tite Connector	6
7	Float	6
8	Manual Mode	9
9	Automatic Mode	10
10	Monitor Mode	12
11	Probe Check Well	17

Important

U. S. Federal law restricts this device to sale by or on the order of a physician.

Read and understand this *Medi-Therm III Operating Manual* and all *Safety Precautions* (see page I, section I.0 and pp. 14–15, section 8.0) prior to using the Medi-Therm III Hyper/Hypothermia Machine.

Receiving Inspection

Refer to the *Medi-Therm III Service Manual* for *Receiving Inspection* and *Check-out Procedures*.

If you have any questions, contact Gaymar's Technical Service Department for assistance.

Telephone: 1 800 828-7341
(716) 662-2551

Fax: (716) 662-8795

1.0 Safety Precautions

Read and understand this operating manual and all precautions listed below prior to using the Medi-Therm III Hyper/Hypothermia Machine.

▲ DANGER

Do not use the Medi-Therm III machine in the presence of flammable anesthetics. **Risk of explosion can result.**

▲ WARNING

- If the patient's temperature is not responding or does not reach the prescribed temperature in the prescribed time or deviates from the prescribed temperature range, notify the attending physician promptly. **Failure to notify the physician promptly may result in serious injury or death.**
- Power interruption will cause the Medi-Therm III machine to go into a standby mode, resulting in no therapy to the patient. Follow instructions for desired mode to resume operation. **Failure to resume therapy could result in serious injury or death.**
- When performing the *PROBE CHECK* (p. 18, 10.1.2, item 4), use a protective sheath on the probe. **Failure to use a sheath could result in cross-contamination.**
- A physician's order is required for setting blanket temperature and for continued use of equipment. At least every 20 minutes or as directed by a physician, check patient's temperature and skin condition of areas in contact with blanket; also, check blanket water temperature. Pediatric, temperature-sensitive, and operating room patients should be checked more frequently. **Failure to monitor patient may result in skin damage or inappropriate patient temperature.**
- Avoid placing additional heat sources between the patient and blanket. **Skin damage may result.**

(continued next column)

▲ WARNING

- Prevent excessive and/or prolonged tissue pressure and shearing forces, especially over bony prominences. **Skin damage may result.**
- Keep the area between the patient and the blanket dry. **Excessive moisture may result in skin damage.**
- Do not tip machine over without first draining the water out and unplugging the power cord. **Damage to the machine or electrical shock can result.**
- Repairs should be performed by qualified personnel such as certified biomedical electronics technicians or certified clinical engineers familiar with repair practices for servicing medical devices, and in accordance with the *Medi-Therm III Service Manual*. Do not attempt repairs to Gaymar medical equipment unless you possess these skills. **Damage to the machine or malfunction may otherwise result.**

▲ CAUTION

- Fill with distilled water only. **Failure to use distilled water may result in poor machine performance.** Do not use alcohol. Alcohol may accelerate blanket deterioration. Do not operate without water, since damage to internal components may result. Do not overfill. Overfilling may result in overflow because the water in the blanket drains back into the machine when the machine is turned off.
- Place a dry absorbent sheet between the patient and the blanket when using all-vinyl blankets. **Moisture may accumulate which may result in skin damage.**

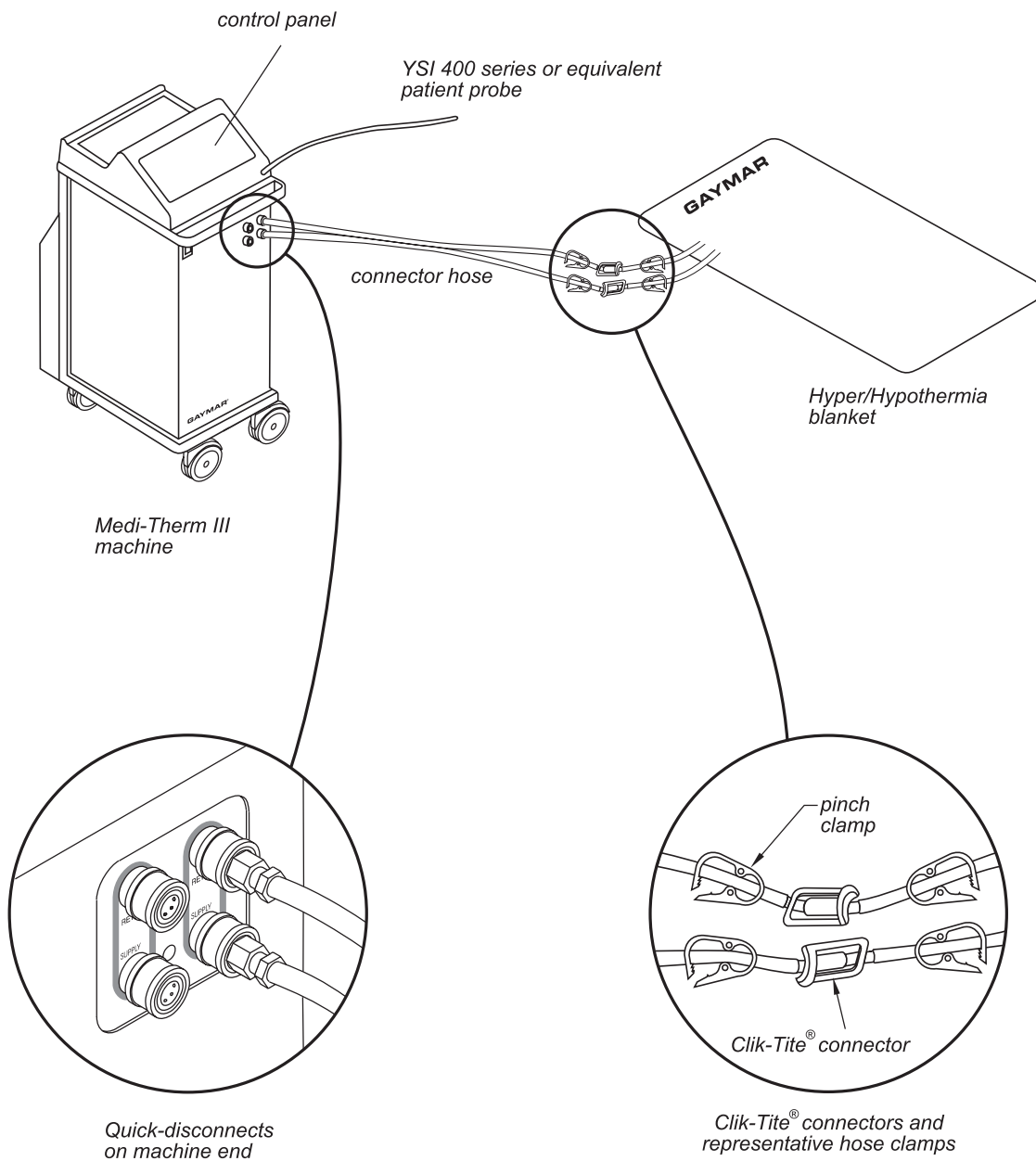

Figure 1—Medi-Therm III Hyper/Hypothermia System

2.0 Description

This manual describes the operation of the Medi-Therm III Hyper/Hypothermia machine.

The Medi-Therm III Hyper/Hypothermia machine provides a means of regulating patient temperature by supplying temperature-controlled water through a connector hose to a Gaymar Hyper/Hypothermia blanket. The companion blanket provides the interface for heating or cooling the patient. A patient probe senses patient temperature.

The Medi-Therm III machine, Hyper/Hypothermia blanket, connector hose, and patient probe comprise the Medi-Therm III system (fig. 1).

Please read and understand the precautions on page 1 and the following operating instructions before attempting to use the Medi-Therm III system. In addition, we recommend you request in-service training from your Gaymar representative.

3.0 Features

Please familiarize yourself with the location and purpose of the features (fig. 2) before reading the start-up procedures or attempting to operate the Medi-Therm III Machine.

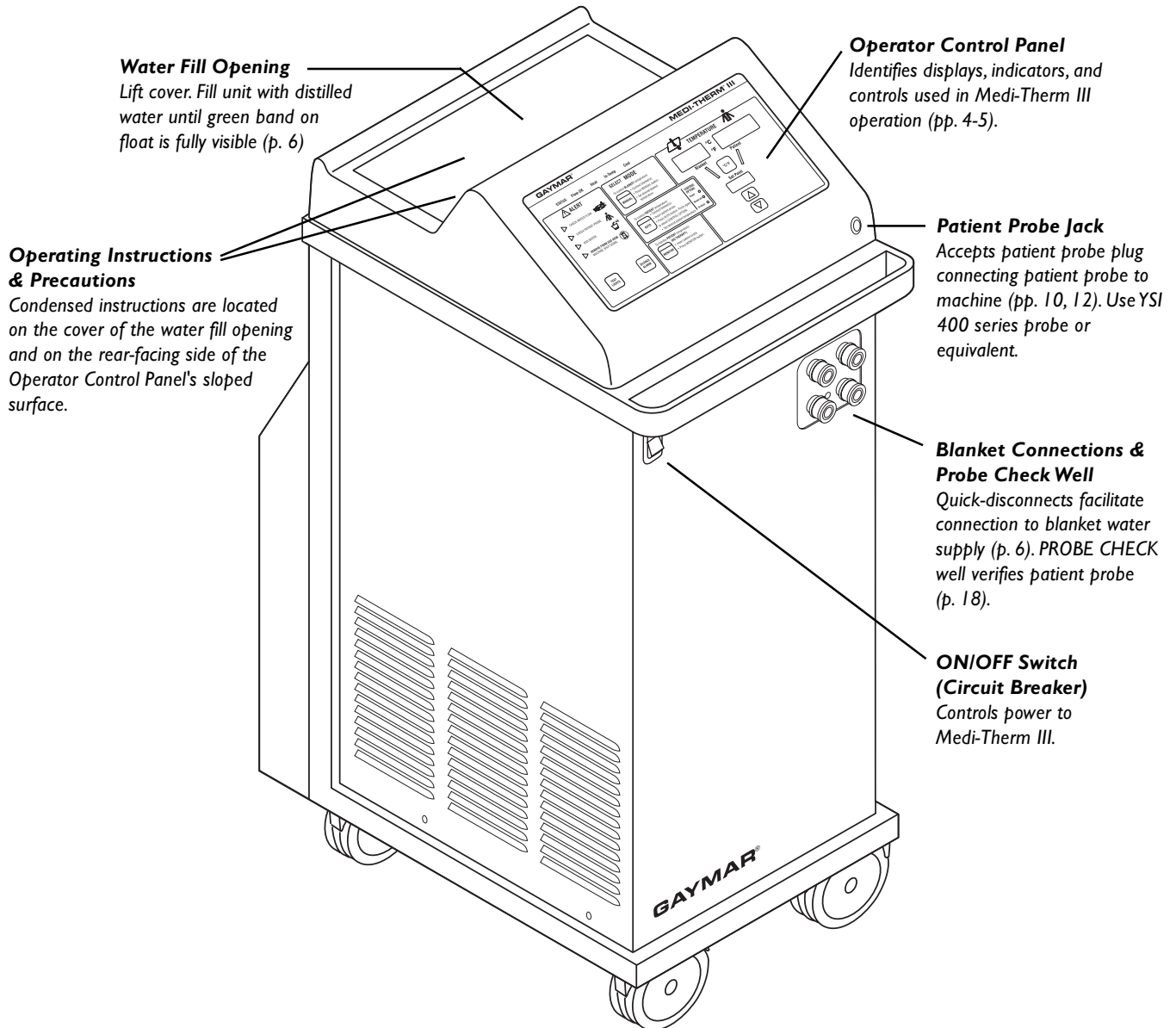

Figure 2—Medi-Therm III features

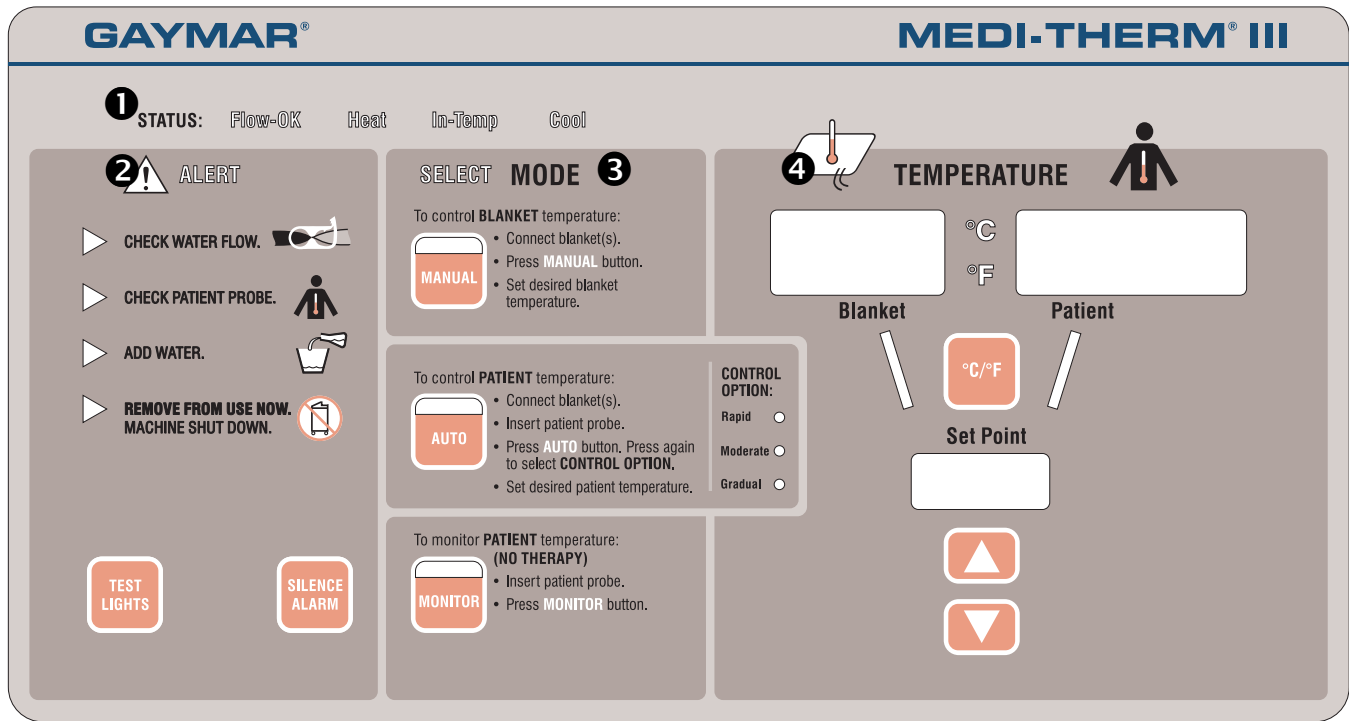

Figure 3—Medi-Therm III Control Panel

4.0 Operator Control Panel

The control panel is divided into sections according to function and use. The principal panel sections are identified in figure 3.

1 STATUS SECTION

STATUS displays light to indicate both the machine’s flow status and how the blanket water temperature is being controlled to reach the desired temperature setting. **STATUS** displays function in both **MANUAL** and **AUTO** modes.

FLOW-OK indicates blanket water is flowing adequately.

HEAT indicates blanket water is being heated. The maximum blanket temperature is 42°C (107.6°F).

IN-TEMP indicates the Medi-Therm III is controlling temperature at the desired setting.

COOL indicates blanket water is being cooled. Minimum blanket temperature is 4°C (39.2°F).

2 ALERT SECTION

 **ALERT** indicators light when some form of operator action is required. In addition to the visual indicator, an audible alarm may sound. **ALERT** controls allow the Medi-Therm III operator to test panel lights or to silence the audible alarm.

 **CHECK WATER FLOW** indicates the flow of water to the blanket has been restricted. The operator can choose whether an audible alarm accompanies this alert. (p. 7, section 5.6)

 **CHECK PATIENT PROBE** indicates the patient probe is sensing an abnormal patient temperature (below 29°C [84.2°F] or above 45°C [113°F]). It may indicate the patient probe has become dislodged, an incorrect probe is being used, or a probe has become defective. An audible alarm accompanies this alert.

 **ADD WATER** indicates the water reservoir is filled to less than the recommended level.

 **REMOVE FROM USE NOW / MACHINE SHUTDOWN** indicates the Medi-Therm III has shut down due to blanket water temperature exceeding either the high or the low limit. An audible alarm accompanies this alert. **Remove the Medi-Therm III machine from use immediately.**

TEST LIGHTS confirms that all indicator lights and digital displays are working, and that the audible alarm is functioning. The displays flash and the audible alarm sounds as long as the **TEST LIGHTS** button is pressed.

SILENCE ALARM temporarily silences the audible alarm. The alarm will reactivate in approximately 5 minutes if the condition persists.

NOTE: The **SILENCE ALARM** button will **not** function if the **REMOVE FROM USE NOW / MACHINE SHUTDOWN** indicator is lit.

3 MODE SECTION

The **SELECT** indicator lights when a choice of operating modes is required. **MODE** buttons select the desired operating mode. Patient therapy is provided in either **MANUAL** or **AUTO** mode. A third mode, **MONITOR**, may be used to monitor patient temperature without providing therapy. After the mode button is pressed, the indicator at the top of the mode button lights. In **AUTO** mode, one of three additional **CONTROL OPTION** indicators light.

MANUAL selects the manual mode of operation. In **MANUAL** mode, the operator must observe patient temperature and adjust the blanket water set point temperature to obtain the desired results.

AUTO selects the automatic mode of operation. In **AUTOMATIC** mode, the operator sets the desired temperature and the patient temperature is automatically regulated to the operator specified set point. Automatic

cooling can be adjusted to **RAPID**, **MODERATE**, or **GRADUAL** rates by pressing the **AUTO** button again.

MONITOR selects the monitor mode of operation. In **MONITOR** mode, the operator may monitor patient temperature without providing therapy.

4 TEMPERATURE SECTION

TEMPERATURE displays identify **BLANKET**, **PATIENT**, and **SET POINT** temperatures.

BLANKET indicates the actual temperature of the water being delivered to the blanket. This display is illuminated when **MODE** is set to either **MANUAL** or **AUTO**.

PATIENT indicates actual patient temperature as sensed by the probe connected to the patient probe jack. This display is illuminated when **MODE** is set to **MANUAL**, **AUTO**, or **MONITOR** and a patient probe is plugged into the **PATIENT PROBE** jack.

SET POINT indicates the desired **SET POINT** temperature. When operating in **MANUAL** mode, pressing the **SET POINT** button (“∇” or “Δ”) sets the desired **BLANKET** water temperature. When in **AUTO** mode, pressing the **SET POINT** button sets the desired patient temperature.

°C/°F displays the temperature in either degrees Celsius (°C) or Fahrenheit (°F). Pressing the **°C/°F** button will display the corresponding indicator.

5.0 Start-up Procedure

For your convenience, condensed versions of the following instructions have been permanently mounted on the cover of the water fill opening and on the rear-facing side of the Operator Control Panel's sloped surface.

Perform the following start-up procedure each time the Medi-Therm III system is placed in operation:

5.1 Close Pinch Clamps

Pinch clamps are provided on both the connector and blanket hoses to prevent water spillage when blankets are changed (fig. 4).

Close the pinch clamps on the connector hose and Hyper/Hypothermia blanket.

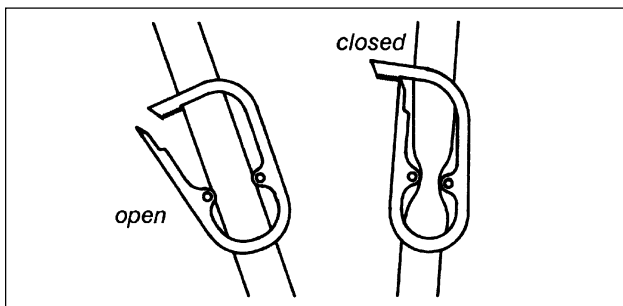

Figure 4—Pinch Clamps

5.2 Attach Blanket

Attach the Hyper/Hypothermia blanket to the Medi-Therm III machine (fig. 1, p. 2):

- a. Connect a Gaymar Model DBK9 connector hose to the Medi-Therm III machine. The hose is ten feet long. It has quick-disconnect (metal) fittings for the Medi-Therm III machine end and Clik-Tite® (plastic) connectors for the blanket end.

To connect the hose, attach one quick-disconnect fitting to the *RETURN* machine connection (top) and one to the *SUPPLY* (bottom). See figure 5. To insure a tight connection, push the retaining collar toward the cabinet and insert the quick-disconnect fitting firmly. While holding the fitting, allow the retaining collar to snap back into position. Check to make sure the fitting is fully engaged by tugging firmly on the hose fitting.

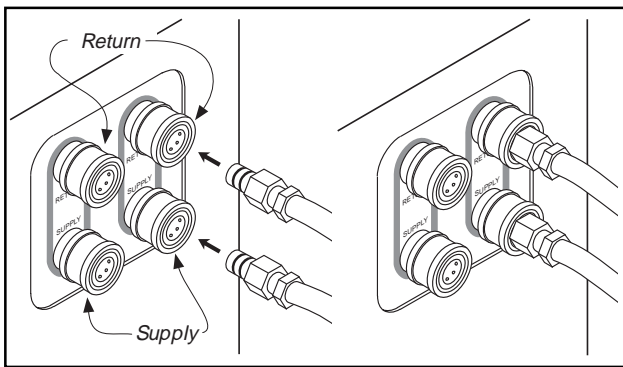

Figure 5—Quick-disconnects

- b. Attach the two Clik-Tite connectors (fig. 6) on the connector hose to the blanket. Insert the male fitting into the female. When fittings are fully seated, snap the locking ring into place to assure a positive lock.

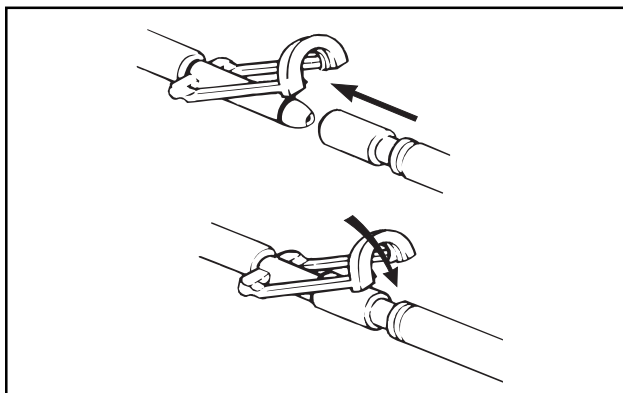

Figure 6—Clik-Tite Connector

5.3 Open All Pinch Clamps

Open all pinch clamps on the connector hose and the Hyper/Hypothermia blanket.

Failure to open the pinch clamps will prevent water flow and will trigger the *CHECK WATER FLOW* alert.

5.4 Check Water Level

Check to make sure water is at the proper level by raising the cover on the water fill opening. Fill with distilled water until the green band on the float is fully visible (fig. 7).

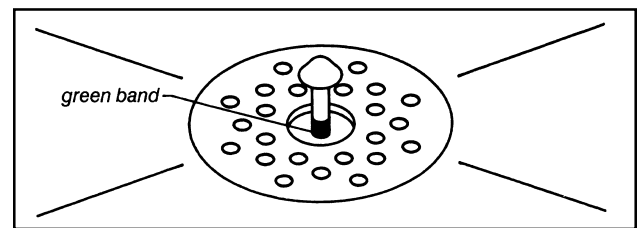

Figure 7—Float, showing proper water level

⚠ CAUTION

Add distilled water only. Failure to use distilled water may result in poor machine performance.

Do not use alcohol, which may accelerate blanket deterioration.

Do not operate without water, since damage to internal components may result.

Do not overfill. Overfilling may result in overflow because the water in the blanket drains back into the machine when the machine is turned off.

5.5 Connect Power/Turn Machine On

If the machine is not already plugged in, insert the power cord plug into a properly grounded AC receptacle at this time. Press the *ON/OFF* Switch to the *ON* position.

When first turned on, the Medi-Therm III enters its standby mode:

- the *ON/OFF* switch will light;
- the machine will beep once;
- the *SELECT* heading will light;
- the *BLANKET*, *PATIENT*, and *SET POINT* temperature displays will show dashes; and
- the °C or °F indicator will light, depending on the scale last selected.

NOTE: If the *ADD WATER* indicator lights, add distilled water until the green band on the float is visible.

5.6 Check Water Flow Alert Audible Alarm Preference

The operator can choose whether to have an audible alarm accompany a *CHECK WATER FLOW* alert visual indication (in the event the blanket water flow becomes restricted). As set from the factory, the visual alert condition is not accompanied by an audible alarm.

To change the audible preference to *ON*:

1. Turn the machine off.
2. Press and hold the *SILENCE ALARM* button.
3. Turn the machine on while continuing to depress the *SILENCE ALARM* button for at least one second.
4. To check audible operation, press the *MANUAL* mode button. Bend the blanket hose (to restrict water flow) until the *CHECK WATER FLOW* and *ALERT* indicators light. The audible alarm should sound.

The new preference (i.e., audible alarm *ON*) will be remembered by the machine even when power is off.

To change the audible preference to *OFF* again, repeat steps 1-3 and insure non-operation of the audible tone using step 4 above.

NOTE: If the audible preference is *ON*, pressing the *SILENCE ALARM* button will temporarily silence

the audible alarm for 5 minutes if a *CHECK WATER FLOW* condition exists.

5.7 Perform Indicator Light Test

Since machine indicators are essential to proper machine operation, you should test the indicator lights each time the machine is placed in operation. Perform this test by pressing and holding the *TEST LIGHTS* button.

While holding the *TEST LIGHTS* button down, verify the following occurs:

- the right and left halves of the display panel light alternately;
- the four status legends (*FLOW-OK*, *HEAT*, *IN-TEMP*, and *COOL*) light;
- the *ALERT* legend and its four (triangular) indicators light;
- the three mode legends, *SELECT* heading, and three *AUTO/CONTROL OPTION* legends light;
- the three temperature displays (*BLANKET*, *PATIENT*, and *SET POINT*) indicate 888, 888.8, and 888.8, respectively;
- the two temperature control legends (°C and °F) and the two lines connecting *SET POINT* to both the *BLANKET* and *PATIENT* display light;
- the audible alarm sounds.

If any indicator does not light, or the alarm does not sound, **remove the machine from use.**

This completes the start-up procedures for the Medi-Therm III machine. Please proceed to sections 7.0 through 7.3 for the operating instructions for *MANUAL*, *AUTO* and *MONITOR* modes.

6.0 Shutdown Procedure

When therapy is completed, turn off the Medi-Therm III machine. Close pinch clamps before disconnecting the blanket.

7.0 Modes of Operation

Read and understand the contents of these *Operating Instructions* and associated precautions before using the Medi-Therm III machine. Any application of the Hyper/Hypothermia System must be under the direction of the attending physician.

▲ WARNING

- If the patient's temperature is not responding or does not reach the prescribed temperature in the prescribed time or deviates from the prescribed temperature range, notify the attending physician promptly.

Failure to notify the physician promptly may result in serious injury or death.

- Power interruption will cause the Medi-Therm III machine to go into a standby mode (see item 5.5, p. 7), resulting in no therapy to the patient. Follow instructions for desired mode to resume operation.

Failure to resume therapy could result in serious injury or death.

The Medi-Therm III machine is designed to operate in three (3) modes:

- *MANUAL* (blanket temperature control),
- *AUTO* (automatic patient temperature control), and
- *MONITOR* (patient temperature monitoring).

Some applications may require a second blanket in order to achieve additional or more rapid heating or cooling. For these situations, a second blanket may be connected to the machine. The rate of patient heating or cooling may also be increased by positioning half- and full-size blankets so that greater body surface is in contact with the blankets.

NOTE: When connecting a second blanket to the Medi-Therm III machine, check the water level (see *Start-up Procedure*, pp. 5-7) **prior** to connecting the additional blanket.

7.1 Manual Mode (To Control Blanket Temperature)

When operating in the *MANUAL* mode, the Medi-Therm III machine regulates the *BLANKET* water temperature to the selected *SET POINT*. A temperature sensor within the machine monitors water temperature, and the machine heats or cools the blanket water as required to bring it to the *SET POINT* temperature.

In *MANUAL* mode, the operator must observe the patient's temperature and manually adjust the blanket temperature to obtain the desired results.

To operate in *MANUAL* mode:

- ① Perform all start-up procedures (pp. 5-7).
- ② Press the *MANUAL* mode button. The upper window on the *MANUAL* button will light.

The *BLANKET* display will indicate blanket water temperature. The *SET POINT* display will indicate the default temperature (32°C [89.6°F]) at start-up, until selecting the *SET POINT* temperature in step 4 below.
- ③ If desired, change the temperature scale by pressing the °C/°F button.
- ④ Adjust the *SET POINT* display to the prescribed blanket temperature setting by pressing the “∇” or “Δ” button to decrease or increase the *SET POINT*.

The *STATUS* display will indicate *HEAT* or *COOL* while the machine is heating or cooling the blanket water. When the blanket temperature stabilizes (within 1°C [1.8°F] of the *SET POINT* temperature), the *IN-TEMP* indicator will light indicating that the desired blanket water temperature is being maintained.

NOTE: When the Medi-Therm III machine is turned on, the machine set point defaults to 32°C (89.6°F) when *MANUAL* mode is selected, or 37°C (98.6°F) when *AUTO* mode is selected.

Once a *SET POINT* temperature for a mode has been selected, it is retained for that mode until the *SET POINT* temperature is changed or the machine has been turned off. **The *SET POINT* temperature in one mode does not affect the *SET POINT* temperature in another mode.**

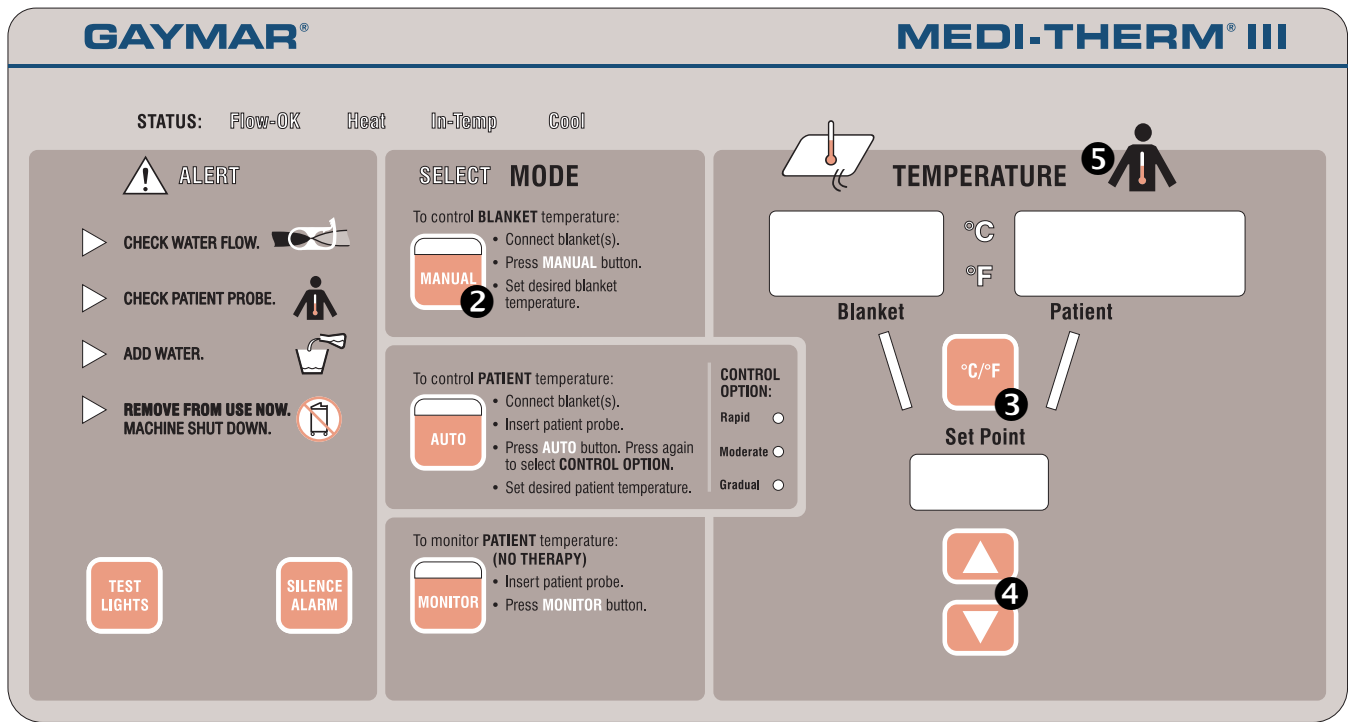

Figure 8—Manual Mode

5 **WARNING**

At least every 20 minutes, or as directed by a physician, check the patient's temperature and skin condition of areas in contact with blanket; also check *BLANKET WATER* temperature display.

Failure to monitor patient may result in skin damage or inappropriate patient temperature.

NOTE: While operating in the *MANUAL* mode, the patient probe may be used to monitor the patient's temperature.

To use this Medi-Therm III feature, insert sensing end of patient probe into patient and tape

securely to prevent accidental dislodgment. Insert plug end of patient probe into *PATIENT PROBE* jack. Make sure probe plug is fully seated. The *MANUAL* mode switch must be pressed.

Use YSI 400 Series Probes or equivalent. If in doubt that the correct probe is being used and is operating properly, perform a *PROBE CHECK* test (p. 18, 10.1.2, item 4).

Patient temperature will be indicated on the *PATIENT* temperature display.

If the patient probe senses an abnormal patient temperature (below 29°C [84.2°F] or above 45°C [113°F]), the *CHECK PATIENT PROBE* alert will light and an audible alarm will sound. This condition may indicate the patient probe has become dislodged, an incorrect probe is being used, or the probe has become defective (see *Alerts*, pp. 18-19).

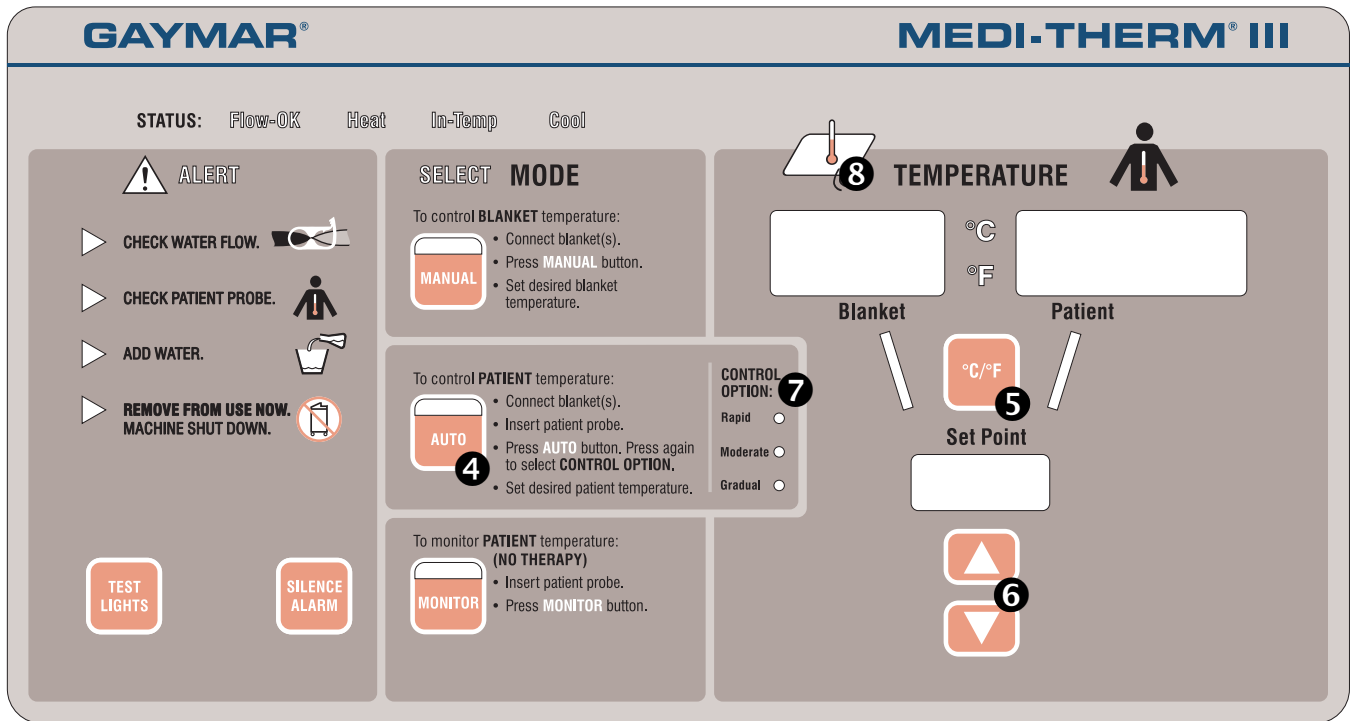
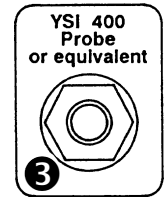

Figure 9—Automatic Mode



7.2 Automatic Mode (To Control Patient Temperature)

When operating in the *AUTO* mode, the Medi-Therm III automatically regulates the patient's temperature to the selected *SET POINT*. The machine constantly compares actual patient temperature with the *SET POINT* value, and automatically adjusts the *BLANKET* water temperature so that the desired patient temperature is achieved.

To operate in *AUTO* mode:

- ① Perform all start-up procedures (pp. 5-7).
- ② Insert sensing end of patient probe into patient and tape securely to prevent accidental dislodgment.
- ③ Insert plug end of patient probe into *PATIENT PROBE* jack.

NOTE: Make sure probe plug is fully seated. **Use YSI 400 series probes or equivalent.** If in doubt that the correct probe is being used and is operating properly, perform a *PROBE CHECK* test (p. 18, 10.1.2, item 4).

- ④ Press the *AUTO* mode button. The upper window on the *AUTO* button will light. The *CONTROL OPTION/RAPID* will light.

NOTE: To prevent accidental triggering of the *CHECK PATIENT PROBE* alert, place probe in patient and wait five (5) minutes before pressing *AUTO* mode button.

The *BLANKET* display will indicate blanket water temperature. The *PATIENT* display will indicate patient temperature. The *SET POINT* temperature will indicate the default temperature (37°C [98.6°F]) at start-up, until selecting the *SET POINT* temperature in step 6 (p. 11).

- ⑤ If desired, change the temperature scale by pressing the *°C/°F* button.

- 6 Adjust the *SET POINT* display to the prescribed patient temperature setting by pressing the “∇” or “Δ” button to decrease or increase the *SET POINT*.

NOTE: When the Medi-Therm III machine is turned on, the machine set point defaults to 32°C (89.6°F) when *MANUAL* mode is selected or 37°C (98.6°F) when *AUTO* mode is selected.

Once a *SET POINT* temperature for a mode has been selected, it is retained for that mode until the *SET POINT* temperature is changed or the machine has been turned off. **The *SET POINT* temperature in one mode does not affect the *SET POINT* temperature in another mode.**

- 7 The unit will heat or cool as required to bring the patient temperature to the *SET POINT*. The rate of cooling is user adjustable through the use of the *CONTROL OPTION*. The rate of heating is not adjustable. The unit applies heat at a maximum rate with the maximum water temperature limited to 42°C (107.7°F) regardless of the *CONTROL OPTION* selected.

The *CONTROL OPTION* defaults to *RAPID* when *AUTO* mode is entered. Select a different *CONTROL OPTION* by pressing the *AUTO* button again.

Rapid—the coldest water is used for cooling— as low as 4°C (39°F). This may not be the most comfortable setting for the patient.

Moderate—cooling water temperature is limited to 15°C (27°F) below *PATIENT TEMPERATURE*. This will provide an improved comfort setting to the patient.

Gradual—cooling water temperature is limited to 10°C (18°F) below *PATIENT TEMPERATURE*. This will provide the maximum comfort to the patient.

8

- At least every 20 minutes, or as directed by a physician, check the patient’s temperature and skin condition of areas in contact with blanket; also check *BLANKET WATER* temperature display.

Failure to monitor patient may result in skin damage or inappropriate patient temperature.

- If the patient probe senses an abnormal patient temperature (below 29°C [84.2°F] or above 45°C [113°F]), therapy will stop, the *CHECK PATIENT PROBE* alert will light and an audible alarm will sound.

This condition may indicate the patient probe has become dislodged, an incorrect probe is being used, or the probe has become defective (see Alerts, pp. 18-19).

NOTE: The *PATIENT* temperature display will flash when the patient’s temperature is more than 1°C (1.8°F) from the *SET POINT* temperature. Such flashing occurs **only** in the *AUTO* mode.

▲ WARNING

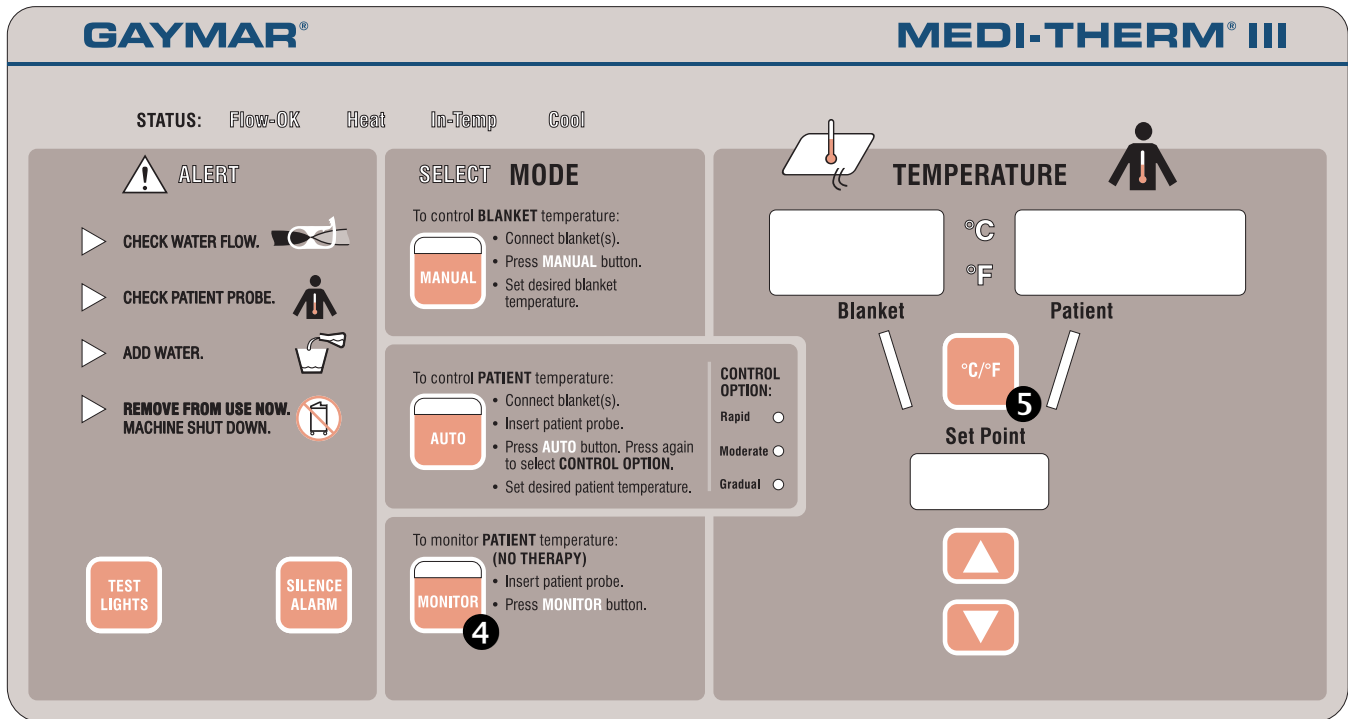
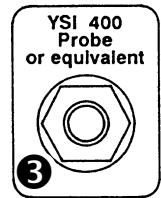

Figure 10—Monitor Mode



7.3 Monitor Mode (Patient Temperature Monitoring, No Therapy)

Press **MONITOR** mode when no patient temperature therapy is required, but monitoring of patient temperature is desired.

To operate in **MONITOR** mode:

- ① Perform steps 5.4, 5.5, and 5.6 of the *Start-up Procedure* (pp. 6-7).
- ② Insert sensing end of patient probe into patient and tape securely to prevent accidental dislodgment.
- ③ Insert plug end of patient probe into the **PATIENT PROBE** jack.

Make sure probe plug is fully seated.
Use YSI 400 Series Probes or equivalent.

If in doubt that the correct probe is being used and is operating properly, perform a **PROBE CHECK** test (p. 18, 10.1.2, item 4).

- ④ Press the **MONITOR** mode button. The upper window on the **MONITOR** button will light. The patient's temperature will be displayed.
- ⑤ If desired, change the temperature scale by pressing the °C/°F button.

NOTE: If the patient probe senses an abnormal patient temperature (below 29°C [84.2°F] or above 45°C [113°F]), the **CHECK PATIENT PROBE** alert will light and sound an audible alarm.

This condition may indicate the patient probe has become dislodged, an incorrect probe is being used, or a probe has become defective (see *Alerts*, pp. 18-19).

REMEMBER ...in *MONITOR* mode, **no therapy** is provided.

8.0 Patient Safety

Use the Medi-Therm III Hyper/Hypothermia machine only under the direction of a physician.

Review the following precautions and procedures prior to each application:

⚠ DANGER

Do not use the Medi-Therm III machine in the presence of flammable anesthetics.

Risk of explosion can result.

⚠ WARNING

- If the patient's temperature is not responding or does not reach the prescribed temperature in the prescribed time or deviates from the prescribed temperature range, notify the attending physician promptly.
Failure to notify the physician promptly may result in serious injury or death.
- Power interruption will cause the Medi-Therm III machine to go into a standby mode, resulting in no therapy to the patient. Follow instructions for desired mode to resume operation.
Failure to resume therapy could result in serious injury or death.
- The Medi-Therm III machine is provided with a means of checking rectal/esophageal temperature probes. When performing the *PROBE CHECK* (p. 18, 10.1.2, item 4), use a disposable protective sheath on the probe.
Failure to use a sheath could result in cross-contamination.

(continued next column)

⚠ WARNING

- A physician's order is required for setting blanket temperature and for continued use of equipment. At least every 20 minutes, or as directed by a physician, check patient's temperature and skin condition of areas in contact with blanket; also, check blanket water temperature. Pediatric, temperature-sensitive and operating room patients should be checked more frequently.
Failure to monitor patient may result in skin damage or inappropriate patient temperature.

PEDIATRICS - The temperatures of infants and children are more responsive to surface heating and cooling than adults. The smaller the patient, the more pronounced the effect because of their higher ratio of skin contact area to body mass.

TEMPERATURE-SENSITIVE PATIENTS - Patients with impaired peripheral blood circulation caused by vascular diseases and patients who are incapacitated may be more sensitive to temperature changes than patients with more normal circulation.

OPERATING ROOM PATIENTS - Patients with poor circulation associated with inadequate heart function, reduction in blood volume, and constriction of peripheral blood vessels may deviate from the normal response to the external application of heat and cold.

- Avoid placing additional heat sources between the patient and blanket.
Skin damage can result.

Heat applied by the blanket can result in a rise in skin temperature at the areas of contact. The additional heat rise due to electrosurgical currents flowing to the dispersive electrode could be sufficient to cause tissue injury. Each thermal effect by itself may be completely safe, but the additive effect may be injurious.¹ **Keep additional heat sources from between the patient and the blanket.**

(continued next page)

▲ WARNING

- Prevent excessive and/or prolonged tissue pressure and shearing forces, especially over bony prominences.

Skin damage may result.

Localized skin injury due to tissue compressed between bony prominences and fluid filled channels has occurred during prolonged cardiovascular procedures at blanket temperatures well below the scientifically established epidermal burn injury threshold.²

Local ischemia can follow the application of pressures exceeding capillary pressure resulting in tissue necrosis. This local effect may be enhanced by generalized impairment of the circulation, local shearing forces and increased metabolic demand because of temperature elevation. Pathological changes may begin in two (2) hours.

- Keep the area between the patient and the blanket dry.

Excessive moisture may result in skin damage.

The application of heating or cooling may affect the toxicity of solutions. Prep solutions have been reported to injure the skin when allowed to remain between patients and water circulating heating blankets during prolonged procedures.³

▲ CAUTION

- Place a dry absorbent sheet between the patient and the blanket when using all-vinyl blankets.

Moisture may accumulate which may result in skin damage.

A dry absorbent sheet placed between the patient and the Hyper/Hypothermia Blanket will provide a sanitary barrier and absorb perspiration. It will also promote more uniform distribution of heat. Vinyl blankets with nonwoven fabric surfaces do not require an absorbent sheet when using the nonwoven side.

REFERENCES

- 1 Gendron, F. G. *Unexplained Patient Burns*. Chap. 5, p. 87, Quest Publishing Co., 1988.
- 2 Scott, Stewart M. *Thermal Blanket Injury in the Operating Room*. Arch. Surg., Vol. 94, p. 181, Feb. 1967; Crino, Marjanne H. *Thermal Burns Caused by Warming Blankets in the Operating Room*. Clinical Workshop, Vol. 29, pp. 149-150, Jan-Feb 1980; Gendron, Francis G. *Journal of Clinical Engineering*, Vol. 5, No. 1, pp. 19-26, January-March 1980; Moritz, A.R. and Henriques, Jr., "F.C. Studies of Thermal Injury II." In *The Relative Importance of Time and Surface Temperature in the Causation of Cutaneous Burns*. Am. J. Path., 23:695, 1947; Stoll, Alice M. and Chianta, Maria A. *Method and Rating System for Evaluation of Thermal Protection*. Aerospace Medicine, Vol. 40, No. 11, pp. 1232-1238, Nov. 1969; Stewart, T. P. and Magnano, S. *Burns or Pressure Ulcers in the Surgical Patient*. Decubitus, Vol. 1, pp. 36-40, 1988.
- 3 Llorens, Alfred S. *Reaction to Povidone-Iodine Surgical Scrub, Scrub Associated with Radical Pelvic Operation*. Am. J. Obstet. Gynecol., pp. 834-835, Nov. 14, 1974; Hodgkinson, Darryl J., Irons, George B. and Williams, Tiffany J. *Chemical Burns and Skin Preparation Solutions*. Surgery, Gynecology & Obstetrics, Vol. 17, pp. 534-536, Oct. 1978.

9.0 Care of Medi-Therm III

As with any precision equipment, proper care and maintenance will insure proper performance and reliability. The following routine maintenance procedures will help insure dependable Medi-Therm III operation.

9.1 Machine Care

⚠ WARNING

Do not tip machine over without first draining the water out and unplugging the power cord.

Damage to the machine or electrical shock can result.

⚠ CAUTION

- Add distilled water only.
- **Failure to use distilled water may result in poor machine performance.**
- **Do not** use alcohol. Alcohol may accelerate blanket deterioration. Alcohol is flammable.
- **Do not** operate without water, since damage to internal components may result.
- **Do not** overfill. Overfilling may result in overflow because the water in the blanket drains back into the machine when the machine is turned off.
- When filling an empty Medi-Therm III machine, add a small amount of germicidal or sanitizer solution to the water (MTA33 liquid, or equivalent). Carefully follow manufacturer’s recommended concentration to prevent algae growth within the Medi-Therm III system and Hyper/Hypothermia blanket.

Do not use too much concentrate, since it will result in “foaming,” which can reduce the blanket efficiency and may damage the circulating pump.

- **Do not** use bleach. Bleach will damage the heating element, which could result in excessive leakage.

- NOTE:
- The Medi-Therm III control panel and top surfaces can be cleaned with a soft cloth lightly dampened with isopropyl alcohol.
 - Clean up any accidental spills immediately—use a cloth lightly dampened with isopropyl alcohol.
 - You may check for clarity of fluid by viewing water flowing through clear vinyl blanket.

9.2 Blanket Care

- Allow the blanket to remain connected to the Medi-Therm III machine for about 10 minutes after the machine has been turned off. This will allow most of the water to drain back into the machine.
- Reusable blankets should be cleaned with a damp cloth and mild detergent. If blankets must be sterilized, use any cold sterilization means, except alcohol. Exposure to harsh chemicals will cause blankets to lose flexibility and reduce their resistance to cracking.
- When storing reusable blankets, they should be rolled loosely. (Do not allow to freeze.) Single-patient use blankets should be discarded after use.
- Reusable blankets can often be repaired using a vinyl patch kit. Do not return blankets to factory for repair.

9.3 Probe Care

- Do not autoclave. If probe must be sterilized, use any cold sterilization means except alcohol, which may accelerate probe deterioration. Always wipe dry.
- Reusable probes may be cleaned with a damp cloth and mild detergent. Always wipe dry. Exposure to harsh chemicals will cause probe to lose flexibility and resistance to cracking.
- Disposable probes should be discarded after use.

9.4 Probe Check Well Care

The *PROBE CHECK WELL* should be cleaned with a small tubular brush and detergent, and then wiped with a commercial disinfectant.

▲ DANGER

When performing the *PROBE CHECK*, use a protective sheath on the probe. (Becton-Dickinson catalog 3700 oral sheath or equivalent).

Failure to use a sheath could result in cross-contamination.

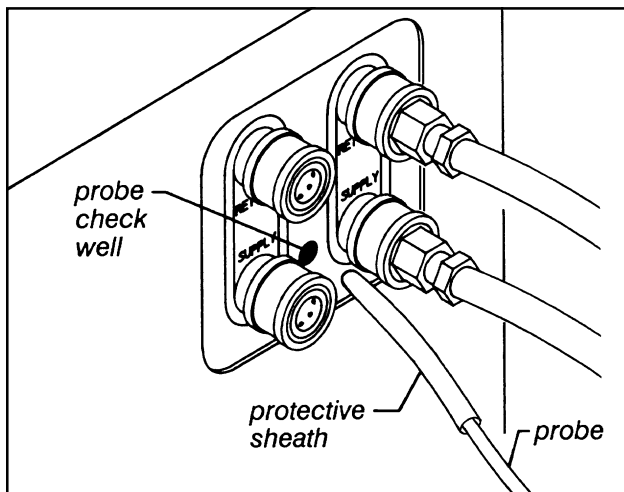

Figure 11—Probe Check Well

9.5 Quick Disconnects

The quick-disconnects joining the connector hose to the machine may become difficult to engage. This problem can be eliminated by applying a silicone base or light machine oil to the outside of the male connector prior to engagement.

9.6 Draining Machine

It is not necessary to drain the Medi-Therm III machine after each use. However, periodic draining is recommended at least once a month.

To lower the water level, close both pinch clamps on the connector hose. Place the end with both Clik-Tite connectors into a sink or pail. Open the pinch clamps. Press the *ON/OFF* switch to *ON* and press *MANUAL* mode button. The machine will pump the water reservoir empty. Press *ON/OFF* button to *OFF* when *CHECK WATER FLOW* lights. After the water is pumped out, do not leave the machine on or it may overheat.

Preventive maintenance and service procedures are described in the *Medi-Therm III Service Manual*. These procedures should be performed by qualified personnel such as certified biomedical electronics technicians or certified clinical engineers.

10.0 Alerts/Troubleshooting

Most Medi-Therm III operating problems are minor and can be corrected by the operator. The following are alerts and troubleshooting details.

⚠ WARNING

Repairs should be performed by qualified personnel such as certified biomedical electronics technicians or certified clinical engineers familiar with repair practices for servicing medical devices, in accordance with the *Medi-Therm III Service Manual*. **Do not** attempt repairs to the Medi-Therm III machine unless you possess these skills.

Damage to the machine, malfunction, or electrical shock may otherwise result.

10.1 Alerts

The Medi-Therm III machine has both visual and audible alert indicators to help you identify machine or operator caused problems. An explanation of these signals and their probable causes follow. Perform corrective action in the sequence listed.

10.1.1 Check Water Flow

Circulation of water through the blanket has been restricted. Air bubbles in the blanket may remain stationary although water is flowing; a few bubbles do not adversely affect operation of the blanket.

To locate and correct the source of low flow:

1. Check that hoses are fully inserted and seated into one *RETURN* (top) and one *SUPPLY* (bottom) connector on the machine. (See *Start-up Procedure*, p. 6.)
2. Check that all pinch clamps are fully open.
3. Check that hoses are not kinked or pinched off. Make sure blanket is flat and not creased. If a blanket is used with patient in sitting position, flow may be pinched off.
4. Confirm that water supply is at proper level.
5. Turn off machine. Close all pinch clamps. Disconnect blanket from connector hose. Direct connector hoses into water fill opening, start machine, and select *MANUAL* or *AUTO* mode. Open connector pinch clamps. If there is still no flow, turn machine off and remove from use.

10.1.2 Check Patient Probe

Indicates that the patient probe is sensing below 29°C (84.2°F) or above 45°C (113°F), and is not a normal patient temperature.

⚠ WARNING

If *CHECK PATIENT PROBE* light comes on, therapy will stop (in *AUTO* mode only), status lights will go out, and no additional heating or cooling will occur until the problem is corrected.

1. *CHECK PATIENT PROBE* audible alarm can be silenced for five minutes while diagnosing problem by pressing *SILENCE ALARM*.
2. *CHECK PATIENT PROBE* alert may sound if machine is placed in *MANUAL*, *AUTO*, or *MONITOR* mode before patient probe has been inserted in patient, since probe will be sensing room temperature. Place probe in patient and wait five (5) minutes before pressing *MANUAL*, *AUTO*, or *MONITOR* mode button.
3. Check probe to make sure it has not become dislodged from patient. Reinsert and tape securely if required. Wait five (5) minutes before pressing *AUTO* mode button.
4. Perform **PROBE CHECK**:
 - a. Insert probe into protective sheath and then into *PROBE CHECK WELL* on front of machine base (fig. 11, p. 17).

⚠ WARNING

When performing the *PROBE CHECK*, use a protective sheath on the probe.

Failure to use a sheath could result in cross-contamination.

- b. Operate machine in *MANUAL* mode with a blanket connected. Adjust *SET POINT* temperature to between 33°C (91.4°F) and 37°C (98.6°F). Wait until machine temperature stabilizes (*IN-TEMP* lights and patient temperature display stabilizes). Blanket and patient temperature displays should read within 2°C (3.6°F) of each other. If not, patient probe may be defective

or incorrect probe is being used.

Use only YSI 400 Series probes or equivalent.

- c. If probe appears defective, try another probe and repeat *PROBE CHECK*. If a new, correct probe does not meet this test, remove machine from use and notify your medical equipment repair department.

10.1.3 Add Water

Check to make sure water is at the proper level by raising the cover on the water fill opening. If green band on float is not visible, fill with distilled water until the green band is visible (fig. 7, p. 6). If green band on float is visible, do not add water—remove machine from use and notify your medical equipment repair department.

⚠ CAUTION

- **Add distilled water only.**
Failure to use distilled water may result in poor machine performance.
- **Do not** use alcohol. Alcohol may accelerate blanket deterioration.
- **Do not** operate without water. Damage to internal components may result.
- **Do not** overfill. Overfilling may result in overflow because the water in the blanket drains back into the machine when the machine is turned off.

10.1.4 Remove From Use Now / Machine Shutdown

This alert indicates that the machine has shut down due to the blanket water temperature exceeding the high or low limit, or if a system error is detected. **Remove machine from use immediately.** Notify your medical equipment repair department.

10.2 Troubleshooting

10.2.1 Blanket Will Not Heat

1. Check that water is circulating through the blanket. If there is no circulation, the *CHECK WATER FLOW* alert should light. If *CHECK WATER FLOW* is lit, refer to *Alerts* section (pp. 18-19) for corrective measures. **Do not fold blankets.**
2. Check that the temperature control is operating by pressing the *MANUAL* mode button and then adjusting the *SET POINT* temperature to at least 2°C (3.6°F) above the indicated blanket temperature. This should cause the *HEAT* indicator to light.

10.2.2 Blanket Will Not Cool

1. Check to see if water is circulating through the blanket. If there is no circulation to the blanket, the *CHECK WATER FLOW* alert should light. If *CHECK WATER FLOW* is lit, refer to *Alerts* section (pp. 18-19) for corrective measures. **Do not fold blankets.**
2. Check that rear and side air vents are not blocked. Inlet and exhaust grills should be kept clear and clean to allow air to circulate freely.
3. Check that the temperature control is operating by changing the *SET POINT* temperature to at least 2°C (3.6°F) below the indicated blanket temperature. This should cause the *COOL* indicator to light.

10.2.3 Machine Will Not Turn On

1. Make sure the power cord is plugged in.
2. Reset the *ON/OFF* switch (circuit breaker) by turning it first off, then on.
3. If the machine still does not turn on, remove machine from service and notify your medical equipment repair department.

10.2.4 On/Off Switch Is Turned On, But Control Panel Is Dark And No Operating Sound Is Coming From Machine

Remove machine from use and notify your medical equipment repair department.

11.0 Blankets/Accessories

Adult and pediatric size blankets are available in all vinyl or vinyl with nonwoven fabric surfaces.

SINGLE PATIENT USE BLANKETS, PLASTIC WITH NONWOVEN FABRIC

- DHP810 O.R. Table and General Use
25" x 64"
- DHP812 Pediatric General Use
22" x 33"
- DHP813 Adult General Use
30" x 64"

SINGLE PATIENT USE BLANKETS, ALL VINYL

- DHP901 Adult General Use
25" x 69"
- DHP902 Pediatric General Use
25" x 36"

REUSABLE BLANKETS, HEAVY DUTY VINYL

- HP7010 Adult General Use
25" x 69"
- HP7020 Pediatric General Use
25" x 36"

All blankets and wraps require reusable DBK9 connector hoses.

ACCESSORIES

- DBK9 Connector Hose
10'
- HBX8 Hose Extension
10'
- PAT101 Adult Reusable Probe
(YSI 400 series)
- PAT102 Pediatric Reusable Probe
(YSI 400 series)
- DP400CE Disposable Probe, Adult and Pediatric
(YSI 400 series)
- ADPI0CE Reusable Probe Adaptor
- MTA33 Germicide/Algaecide

12.0 Customer Training

In-service training is recommended and can be arranged through your Gaymar Representative. Comprehensive repair and maintenance training is also available through Gaymar Technical Services (for telephone numbers, see back cover).

13.0 Warranty

The Medi-Therm III Hyper/Hypothermia machine is warranted free of defects in material and workmanship for a period of two (2) years under the terms and conditions of the Gaymar warranty in place at the time of purchase. The compressor portion of the machine carries a five (5) year prorated warranty. Contact Gaymar Technical Service if you have questions about warranty or repair.

GAYMAR®

GAYMAR INDUSTRIES, INC.

10 Centre Drive
Orchard Park, NY
14127-2295

Phone:
1 800 828-7341
(716) 662-2551

FAX:
1 800 993-7890
(716) 662-0748